

## Business Studies

### Museum of Brands Worksheet

This worksheet on Business Studies is for your use as you make your way around the Museum of Brands. As the questions use various parts of the Museum, you may need to go round more than once.

1. The objects in this Museum are either: manufactured and packaged products made to be sold, or advertisements which market these products. Explain whether this Collection represents businesses from primary, secondary or tertiary sectors.

2. Chose a product in the Museum and describe the related businesses which would have been involved in order to produce, manufacture and sell this item.

Primary Production

Secondary Production

Tertiary Production

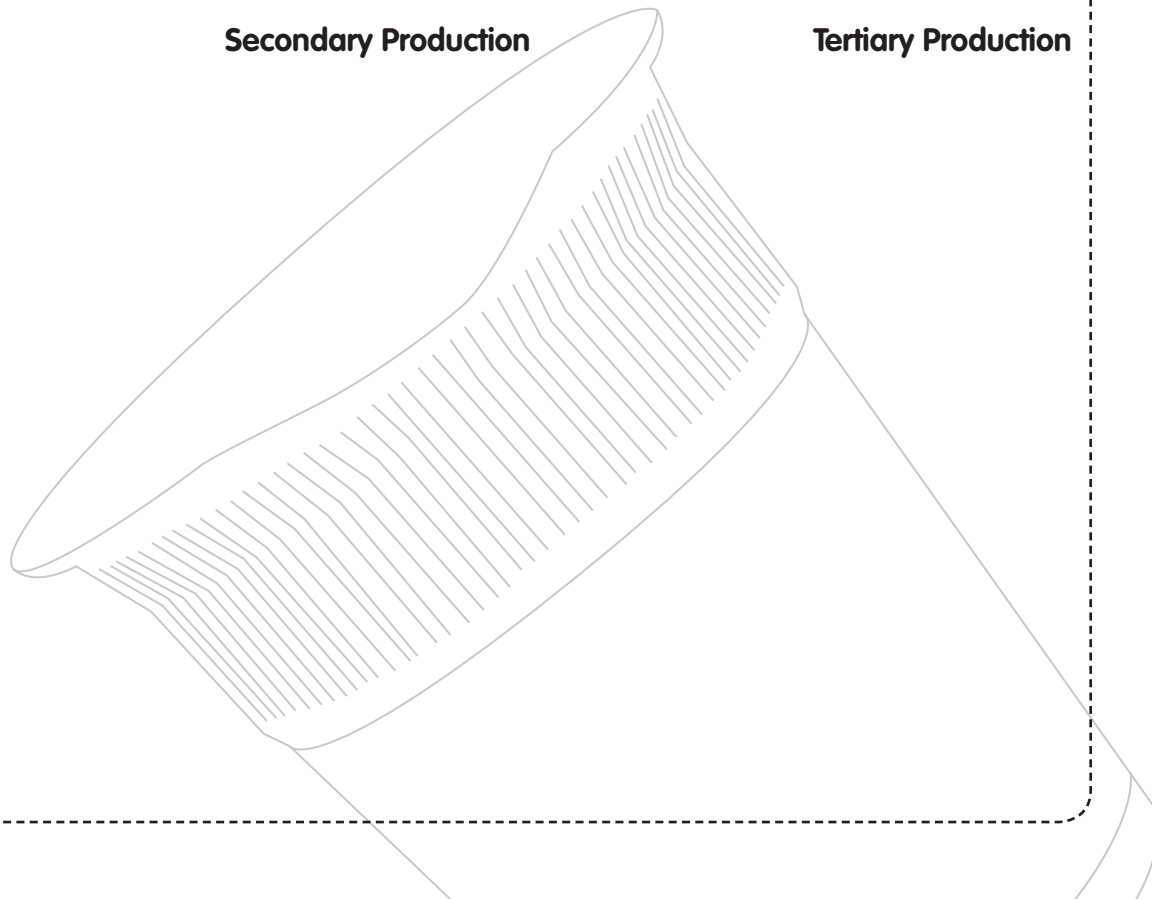

**3.** Businesses use advertising to turn wants into needs, find two examples of a piece of advertising or packaging which communicates that the product is essential to the customer. Below, describe the words and imagery the business use to put across these messages.

Product 1

Product 2

**4.** Businesses need to be flexible and opportunistic in changing times. Find three examples of how different historical events in the Time Tunnel are reflected in the packaging and advertisements on display.

a) Event

Related Product

b) Event

Related Product

c) Event

Related Product

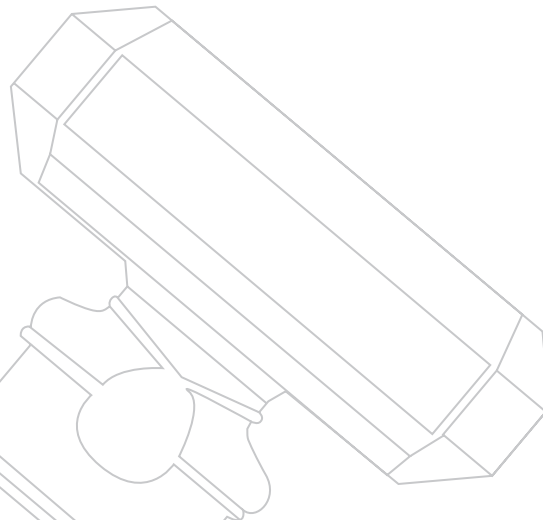

**5.** As found above, historical events can spark new business ventures. Describe why businesses reference current events in their packaging and advertising using one of your examples above

**6.** In the 2000s section of the Time Tunnel, find the cabinet detailing the start of the new Millennium. Using the example of the 'Millennium bug' advertising, describe how this new business has taken advantage of consumer attitudes around the beginning of the century.

**7.** Think of an event or large societal change which happened recently. Imagine two new tertiary businesses which could have sparked in reaction to this event and describe their enterprises below.

**Event**

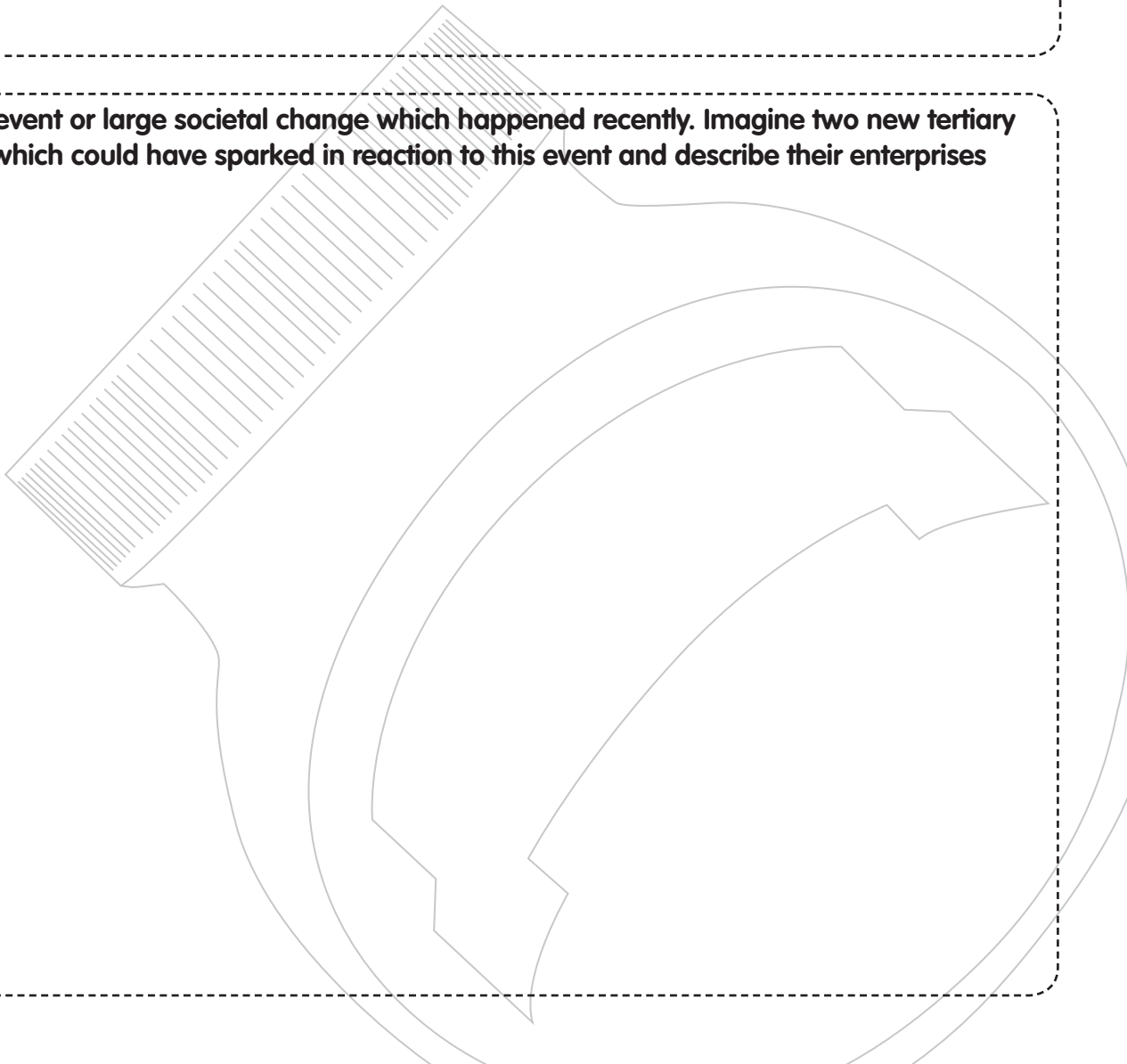

**Business 1**

**Business 2**



## Case Study PG Tips

In the first room of the Branding Hall, find the PG Tips brand evolution display. You will also see a PG Tips advert on the show reel. Fill in the blanks in the chart below to analyse ways in which this business has repositioned their product to stay relevant to their audiences.

Packaging/Advertisement (Drawing or description)	Communicated Message	Consumer profile
	<p>Pre-gest Tea should be taken before meals to aid digestion</p>	
<p>TV Advert on show reel</p>		
		<p>Rise of consumers concerned with animal welfare</p>
		

PG Tips is a brand owned by Unilever. Read this quote from Kate Hearn, Senior Brand Manager at Unilever:

“We’ve listened to our consumers and redesigned our packaging to make the brand more relevant to shoppers, especially the younger consumer. We also believe that the clear, fresh new look, with a bigger and bolder PG tips logo, will make it easier for shoppers to find their favourite tea brand in the busy supermarket aisle.”

Fill out the table below using the information above:

Packaging/ Advertisement	Communicated Message	Consumer

Imagine you are Senior Brand Manager for PG Tips in 2020. The popularity of tea drinking has plummeted and TV ads are no longer watched. In this decade businesses rely on consumer-created advertising, such as social media posts or product placement in vlogs. What three steps would you take to ensure your business will survive?

Step One

Step Two

Step Three

We would love to see work inspired by your visit, please photograph it and share it on our twitter or Instagram @museumofbrands #museumofbrands, or send it to rosehughes@museumofbrands.com